



NTPC TAMILNADU ENERGY COMPANY LTD.
(A 50:50 Joint Venture of NTPC Ltd & TANGEDCO)
VALLUR THERMAL POWER STATION (3x500 MW)

Presentation for

Water Conservation at NTECL Vallur

At Council of Enviro Excellence

NTECL Vallur - Project Synopsis

Capacity	1500 MW (3 x 500 MW)
Land	Total: 1140 Acres Main Plant-470 acres, Ash Dyke-525 acres, Coal/Water pipe corridor- 17.8 acres and Township-45 acres, Creek islands-82.36 acres
Source of Coal	Mahanadi Coal Fields, Central Coal Fields, Eastern Coal Fields, SCCL
Source of Water	Only SEA WATER (20 MLD Reverse Osmosis Desalination Plant)
Cooling System	Closed cycle with IDCTs
Power Evacuation	400 kV Transmission system Gas Insulated Switchyard Total outgoing 6 feeders: 2 feeders of TANTRANSCO and 4 feeders of PGCIL
Consent to Operate	Valid up to 31 March 2027.

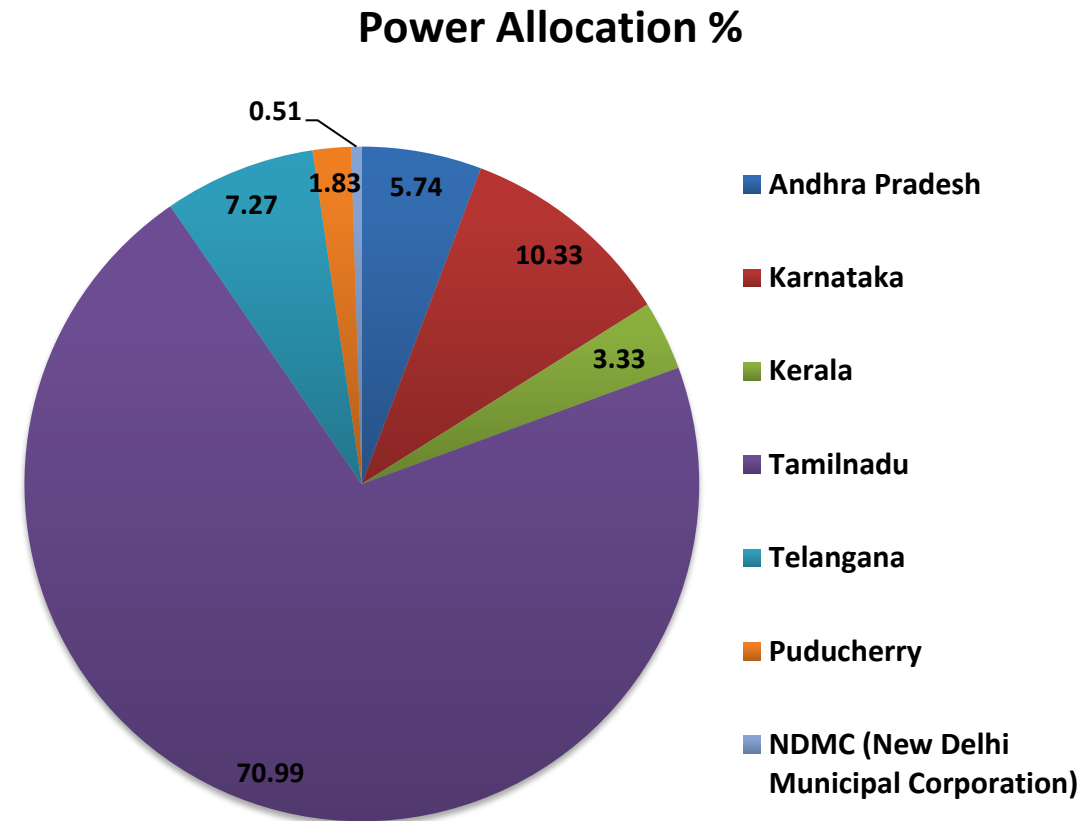

Environmental Friendly Features adopted

- A 4 Km long Spillage free Pipe Conveyor for transportation of coal from Ennore Port.
- A barren salt pan land was converted into a thermal power plant.
- 30 lakhs m³ of ash from the ash ponds of neighbouring thermal plants was used for levelling thus conserving natural soil.
- Least area/MW among NTPC Plants



Entirely Sea Water Based

- Only Unit of NTPC Limited to entirely use only sea water for all purposes (12,150 m³/hr at full load)
 - Desalination plant of 20MLD capacity is operational since inception.
-



Thermal power plants are water intensive industries.

Operating only with sea water is saving huge quantity of fresh water.

Chennai city is facing water scarcity. NTECL Vallur's is a sustainable measure.

Water Consumption details 2023-24

	Unit	2023-24
Total Sea Water Intake	KL	7,89,03,827
Water used for Cooling Purpose	KL	4,40,15,910
Water used for Ash Handling purposes	KL	2,07,13,369
Water used for process – boiler steam and potable	KL	1,41,74,547

*Please note – NTECL is an entirely Sea Water Based Thermal Power station.

Specific Water Consumption and **Zero Liquid Discharge** are not applicable to NTECL as per MoEF&CC notification 28.06.2018.

DESALINATION PLANT SCHEMATIC FLOW

SEA WATER RO O/L - 3 X 275 M3/HR
 BRACKISH WATER RO O/L - 2 X 90 M3/HR
 MIXED BED O/L - 2 X 75 M3

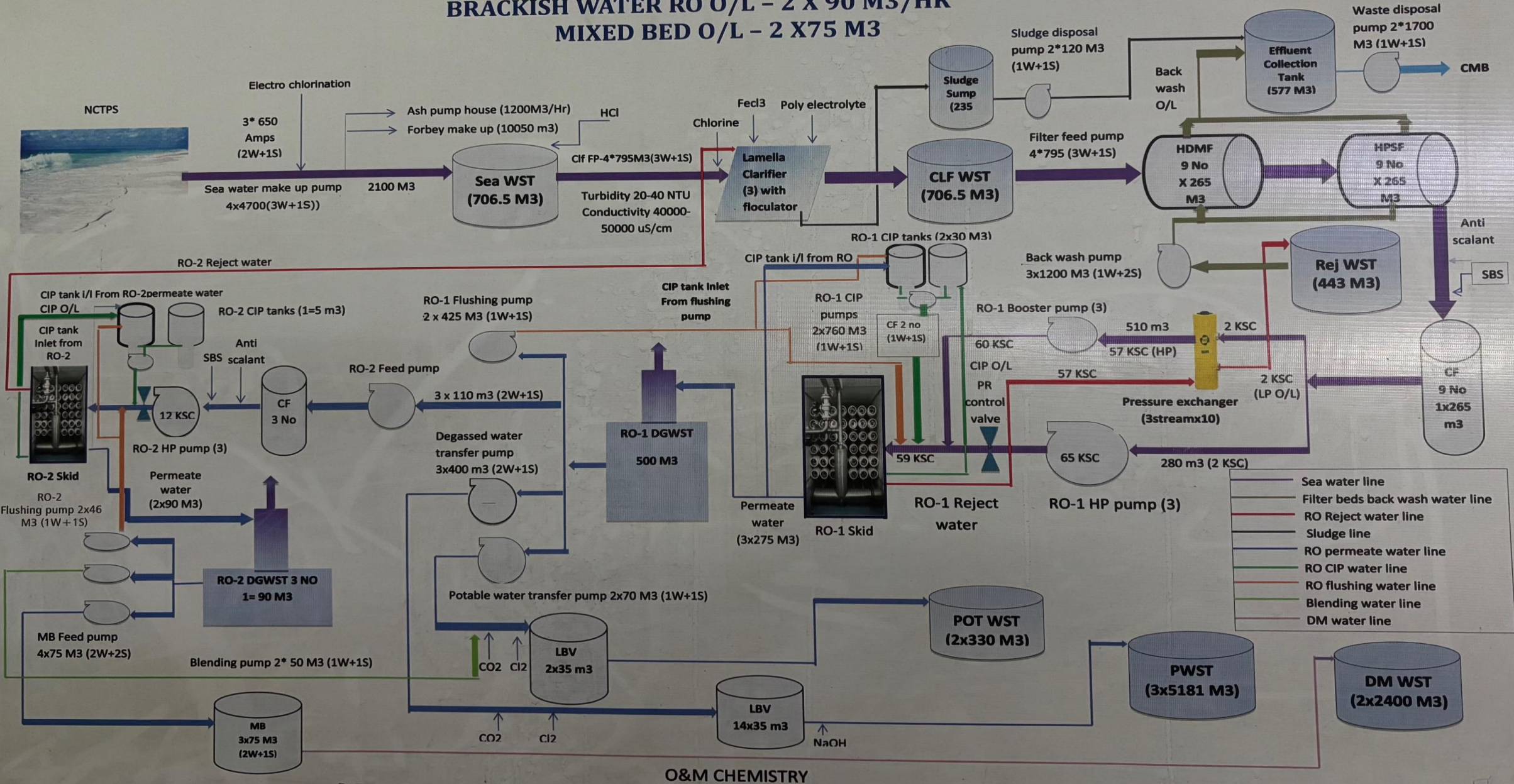

Unique Solar Drinking Water Project

- A Pilot research project of NTECL and NETRA (NTPC Ltd's Research Wing) started in Dec'20
- Capacity : 120 Tonnes/day
- Produces packaged drinking water from sea water (Christened as SURYA NEER)
- Received BIS Certification in July'22
- Green initiative to meet drinking water requirement of entire NTECL Plant and township

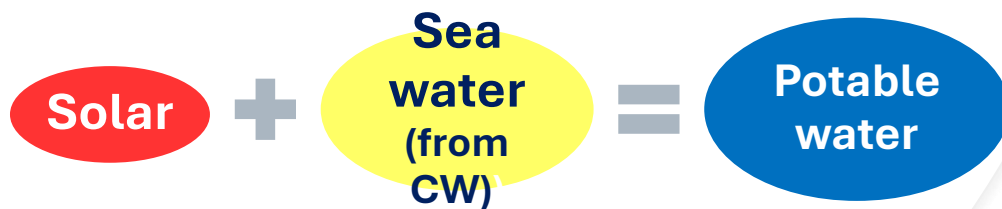

Ash Utilization details at NTECL

NTECL achieved **Highest** Ash Utilization in the year **2023-24**



Sl No	Year	Coal Consumption	Ash Generation	Ash utilization	Ash Utilization	Remarks
1	2024-25 (Till 31.Nov.2024)	4244669	1743801	1781676	102.17%	
2	2023-24	4808438	1828655	2519704	137.79%	✓ Highest till now
3	2022-23	7288322	2946713	2050287	69.58%	(Reduced due to court order)
4	2021 - 22	5956516	2446560	1910629	78.09 %	(Reduction is due to MoP order)
5	2020 - 21	3222366	1276783	1567903	122.80 %	
6	2019 - 20	4253614	1744306	2110981	121.02 %	

Why Ash Handling is Water Efficient at NTECL Vallur?

NTECL has the least Ash - Water Ratio among all NTPC Plants

- ❖ Ash water ratio is maintained at **1:4 to 1:5**.
- ❖ Moreover, entire water used for ash handling is recycled **Sea Water** thereby saving scarce freshwater resource.
- ❖ Ash Handling system is designed to maintain less Ash Water ratio.



Ash water Ratio as per Design

S.No	Different operation Conditions	Ash Water Ratio
1	1B+3FA+3CA	1:3.2
2	1B+2FA+2CA	1:3.68
3	1B+1FA+1CA	1:3.86
4	1FA+1CA	1:3.36
5	2FA+2CA	1:3.36
6	3FA+3CA	1:3.57

Ash Water Recirculation System – Entirely Sea Water

NTECL is recycling up to **2400m³ per hour** of Ash Water from Ash Ponds for Ash handling purposes.

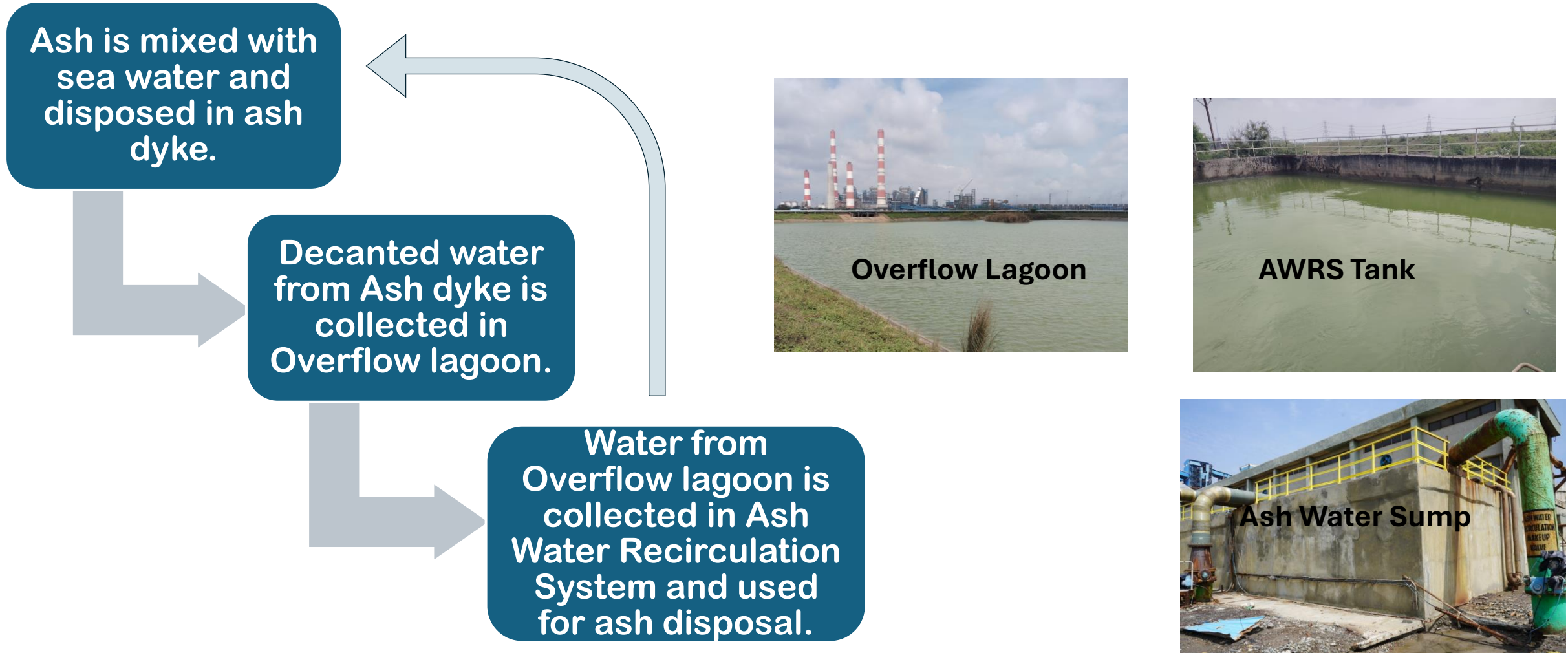

Only one Ash Dyke Lagoon

- NTECL has only one ash dyke lagoon. NTECL has least land area among other power stations of NTPC Ltd.
- Ash from Ash dyke is taken by agencies for low lying area filling and road making.
- NTECL has achieved 100% Ash utilization with just one lagoon. Most thermal power stations operate with minimum 2 ash dyke lagoons.



CSR ACTIVITIES 2023 – Water

*Under **Amrit Sarovar Mission** launched by PM
for rejuvenating 75 water bodies*

Pond Rejuvenation works done in 2023 at
Nalur, Thadaperumbakkam, Sirulapakkam, Poongulam and Thirupalaivanam
Construction of New Ponds at Tiruthani, Pallipatta and Iragi Potai Panchayat
Unions constructed in 2023





World Water Day awareness programmes 2024

- **Water Conservation Activity Award** was announced for employees of NTECL in March 2023 on World Water Day
- **Nukkad Natak** held at near by Government schools.



WATER CONSERVATION AWARDS

MARCH
2023

EXCELLENCE IN WATER USE EFFICIENCY

**TERI – UNDP -IWA Water Sustainability Awards
2022-2023** Presented by Dr Kiran Bedi, Fmr LG Puducherry



MARCH
2022

INNOVATION IN WATER TECHNOLOGY

**TERI – UNDP -IWA Water Sustainability Awards
2021-2022** Presented by Shri Bharat Lal, Secretary Lokpal of India, Former Additional Secretary Jal Jeevan Mission , Ms. Shoko Noda, UNDP Resident Representative in India





THANK YOU